

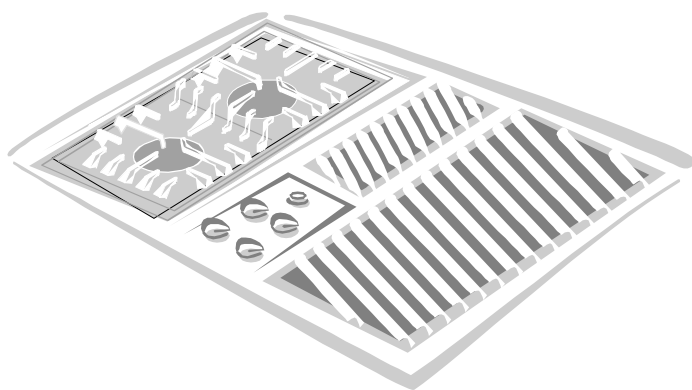

# Owner's Manual

*Covering Amana Cooktop ACC3660*



## Gas Downdraft Cooktop

Keep instructions for future reference.  
Be sure manual stays with cooktop.

<b>Contents</b>	
Important Safety Information .....	3
Cooktop Cartridges .....	5
Adjusting Surface Burner Flame .....	8
Cookware Recommendations .....	9
Using the Cooktop .....	10
Care and Cleaning .....	12
Troubleshooting .....	13
Amana Warranty .....	16

### **Natural Gas ONLY**

**This cooktop is not designed for use with LP/Propane gas**

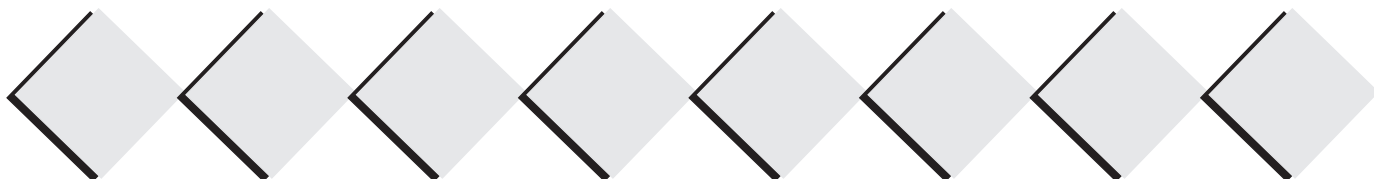

# Thank you for buying an Amana Cooktop!

Please take the time to complete the registration card and return promptly. If registration card is missing, call Amana Consumer Affairs Department. When contacting Amana, provide product information from serial plate located in the cartridge well.

Model Number \_\_\_\_\_  
Manufacturing (P) Number \_\_\_\_\_  
Serial Number (S/N) \_\_\_\_\_  
Purchase Date \_\_\_\_\_  
Dealer Name \_\_\_\_\_  
Dealer Address \_\_\_\_\_  
Dealer Phone \_\_\_\_\_

Keep this manual and your sales receipt together in a safe place for future reference or if warranty service is required.

For answers to questions or to locate an authorized servicer, call **1-800-843-0304 inside USA or 319-622-5511 outside USA. Warranty service must be performed by an authorized servicer.** Amana Appliances also recommends contacting an authorized servicer if service is required after warranty expires.

## Asure™ Extended Service Plan

Amana Appliances offers long-term service protection for this new cooktop. Asure™ Extended Service Plan, covering functional parts, labor, and travel charges, is specially designed to supplement a strong warranty. Call 1-800-528-2682 for information.

## Parts and Accessories

Purchase replacement parts and additional accessories by phone. To order accessories for your Amana product, call 1-800-843-0304 inside USA or 319-622-5511 outside USA.

## Save Time and Money

If something seems unusual, please check *Troubleshooting* section, which is designed to help you solve problems before calling service. If you have a question, call us at **(800) 843-0304** or write us at:

Consumer Affairs Department  
Amana Appliances  
2800 - 220th Trail  
Amana, Iowa 52204

Remember to include model number of your appliance, serial number, date of purchase and your daytime phone number.

*Questions on cooking, cleaning or usage?*  
Refer to  
**Product Assistance at [www.amana.com](http://www.amana.com)**  
or  
**call Consumer Affairs at 1-800-843-0304**

## What You Need to Know about Safety Instructions

Warning and Important Safety Instructions appearing in this manual are not meant to cover all possible conditions and situations that may occur. Common sense, caution, and care must be exercised when installing, maintaining, or operating cooktop.

Always contact your dealer, distributor, service agent, or manufacturer about problems or conditions you do not understand.

## Recognize Safety Symbols, Words, Labels



### DANGER

**DANGER**—Immediate hazards which **WILL** result in severe personal injury or death.



### WARNING

**WARNING**—Hazards or unsafe practices which **COULD** result in severe personal injury or death.



### CAUTION

**CAUTION**—Hazards or unsafe practices which **COULD** result in minor personal injury or product or property damage.

# IMPORTANT SAFETY INFORMATION

## California Safe Drinking Water and Toxic Enforcement Act (Proposition 65)

The Governor of California is required to publish a list of substances known to the state of California to cause cancer or reproductive harm and requires businesses to warn customers of potential exposures to such substances.

This appliance may contain or produce a chemical or chemicals which can cause death or serious illness and which are known to the State of California to cause cancer, birth defects, or other reproductive harm. To reduce the risk from substances in the fuel or from fuel combustion, make sure this appliance is installed, operated and maintained according to the instructions provided.

### CAUTION

**Do not store items of interest to children in cabinets above a cooktop or on the backguard behind the cooktop**—children climbing on the cooktop to reach items could be seriously injured.

### CAUTION

**DO NOT TOUCH SURFACE BURNERS OR AREAS NEAR BURNERS**—Areas near surface burners may become hot enough to cause burns. During and after use do not touch, let clothing or other flammable materials touch or contact surface burners or areas near surface burners until they have had enough time to cool. These areas include the cooktop and backguard.

### CAUTION

To avoid fire or smoke damage,

- remove any flammable materials from area around cooktop. Items like plastic containers and paper manuals can melt or burn.
- clean excess spills as soon as possible.



### **In Case of Fire**

Fires can occur as a result of over cooking or excessive grease. Though a fire is unlikely, if one occurs, proceed as follows:

#### **Surface Burner Fire**

1. Smother the fire with a nonflammable lid or baking soda, or use a Class ABC or BC extinguisher.  
Not water. Not salt. Not flour.
2. As soon as it is safe to do so, turn the surface controls to *OFF*. Turn off power at main circuit breaker or fuse box. Turn off gas supply.

### CAUTION

To avoid risk of delayed or improper ignition, do not obstruct the flow of combustion or ventilation air.

### WARNING

To avoid risk of electrical shock, personal injury or death, verify your cooktop has been properly grounded and always disconnect it from main power supply before servicing.

### WARNING

If the information in this manual is not followed exactly, a fire or explosion may result causing property damage, personal injury or death.

— Do not store or use gasoline or other flammable vapors and liquids in the vicinity of this or any other appliance.

#### **— What To Do If You Smell Gas**

- Do not try to light any appliance.
- Do not touch any electrical switch.
- Do not use any phone in your building.
- Immediately call your gas supplier from a neighbor's phone. Follow the gas supplier's instructions.
- If you cannot reach your gas supplier, call the fire department.

— Installation and service must be performed by a qualified installer, service agency or the gas supplier.

## SAVE THESE INSTRUCTIONS

# IMPORTANT SAFETY INFORMATION (cont'd)

## ALL APPLIANCES

1. Proper Installation—Be sure your appliance is properly installed and grounded by a qualified technician.
2. Never Use Your Appliance for Warming or Heating the Room.
3. Do Not Leave Children Alone—Children should not be alone or unattended in the area where the appliance is in use. They should never be allowed to sit or stand on any part of the appliance.
4. Wear Proper Apparel—Loose fitting or hanging garments should never be worn while using appliance.
5. User Servicing—Do not repair or replace any part of the appliance unless specifically recommended in the manual. All other servicing should be referred to a qualified technician.
6. Storage in or on Appliance—Flammable materials should not be stored near surface units.
7. Do Not Use Water On Grease Fires—Smother fire or flame, or use dry chemical or foam-type extinguisher.
8. Use Only Dry Potholders—Moist or damp potholders on hot surfaces may result in burns from steam. Do not let potholder touch burners. Do not use a towel or other bulky cloth.



## Precautions

- Do not cook food directly on cooktop surface, always use cookware.
- Do not mix household cleaning products. Chemical mixtures may interact with objectionable or even hazardous results.
- Do not put plastic items on warm cooking areas. They may melt and stick.
- Do not slide rough metal objects across cooktop surface. Scratching or metal marking can result.
- Do not leave fat heating unless you remain nearby. Fat can ignite if overheated by spilling onto hot surfaces.
- Do not allow pots to boil dry as this can cause damage to cooking surface and pan.
- Do not use cooktop surface as a cutting board.
- Do not use cooktop for storage or as a display counter.

## SURFACE BURNERS

1. Use Proper Pan Size—This appliance is equipped with one or more surface burners of different sizes. Select utensils having flat bottoms large enough to cover the surface burner. The use of undersized utensils will expose a portion of the burner to direct contact and may result in ignition of clothing. Use of oversized utensils concentrates heat on cooking surface and can cause damage to cooktop. Proper relationship of utensil to burner improves efficiency.
2. Never Leave Surface Burners Unattended—Boilover causes smoking and greasy spillovers that may ignite.
3. Make Sure Reflector Pans or Drip Bowls Are in Place—Absence of these pans or bowls during cooking may subject wiring or components underneath to damage.
4. Protective Liners—Do not use aluminum foil to line surface burner drip bowls or oven bottom, except as suggested in the manual. Improper installation of these liners may result in a risk of electric shock, or fire.
5. Glazed Cooking Utensils—Only certain types of glass, ceramic, earthenware, or other glazed utensils are suitable for cooktop service without breaking due to sudden change in temperature.
6. Utensil Handles Should Be Turned Inward and Not Extended Over Adjacent Surface Burners—To reduce the risk of burns, ignition of flammable materials, and spillage due to unintentional contact with the utensil, the handle of a utensil should be positioned so that it is turned inward, and does not extend over adjacent surface burners.

## VENTILATION HOODS

1. Clean Ventilating Hoods Frequently—Grease should not be allowed to accumulate on hood or filter.
2. When flaming foods under the hood, turn the fan on.

## DELAYED IGNITION

### Surface burners

Burner should ignite within 4 seconds. If burner does not ignite within 4 seconds, turn control knob to OFF and follow directions for installing burner caps in *Adjusting Surface Burners*. Try again. If burner still does not ignite within 4 seconds, contact an authorized servicer.

# SAVE THESE INSTRUCTIONS

# Cooktop Cartridges



## WARNING

To avoid personal injury, do not touch surface burners or area near burners.

- Surface burners may be dark in color even when hot.
- Areas near burners may be hot enough to burn.
- Do not allow clothing or other flammable materials to touch cooktop during or after use.

## Which cartridge should you use?

Your cooktop comes with two gas burner cartridges, but by adding accessories, you can customize your cooktop to suit your specific needs.

CARTRIDGE TYPE	BURNER TYPE	PLACEMENT
<b>Burner (standard)</b>	Two gas burners	Larger front burner, smaller rear burner.
<b>Grill (accessory)</b>	Gas grill burner	Can be installed right side only.
<b>Griddle (accessory)</b>	Gas grill burner	Installed on top of grill accessory.



## WARNING

To avoid personal injury, all controls must be in OFF position before removing or installing cartridges.

## To install the gas burner cartridge:

1. Turn all controls to OFF.
2. Verify surface of cooktop is cool to the touch.
3. Hold cartridge with venturi pointing toward rear of cooktop.
  - If cartridge pan from grill or griddle cartridge is in the well, remove before installing the cartridge.
4. Place end of cartridge into cooktop well with venturi facing rear of well.
  - Lifting cartridge over 45° angle can cause damage to cartridge terminals.
5. Slide cartridge towards rear of cooktop until cartridge engages. Lower front of cartridge into well.
6. Place burner caps on burner
  - The cap should not be loose.
  - The pegs in the burner base should fit into the recess on the underside of burner cap.
  - Cap should be the correct size for each burner base.
  - Cap must be clean and dry for proper ignition.
  - Once cap is properly placed, place grate over cap and burner base .

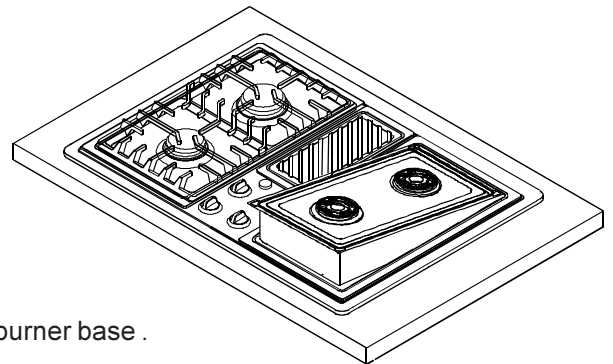

## To remove burner cartridges:

1. Turn all controls to OFF. Make sure surface is cool.
  - Do not tilt cartridge too high.
  - Lifting cartridge over 45° can cause damage to burner venturi.
2. Remove burner grate and cap.
3. Using tab on front of cartridge, lift up slightly.
4. Pull cartridge toward the front of cooktop and carefully lift out.

# Cooktop Cartridges (cont'd)

## Installing the grill or griddle accessory



### WARNING

To avoid personal injury, do not touch surface burners or area near elements.

- Surface burners may be dark in color even when hot.
- Areas near burners may be hot enough to burn.
- Do not allow clothing or other flammable materials to touch cooktop during or after use.



### WARNING

To avoid personal injury, all controls must be in OFF position before removing or installing cartridges.

## 1 Turn all controls to OFF position

Surface of cooktop must be cool to the touch for burners to be handled safely.

Do not cook immediately before installing cartridges or changing cartridges.

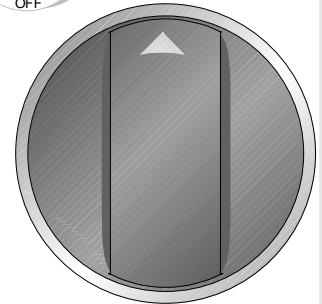

## 2 Place drip pan in cartridge well in cooktop

Place drip pan in bottom of well. Grill can be installed in RIGHT SIDE only.

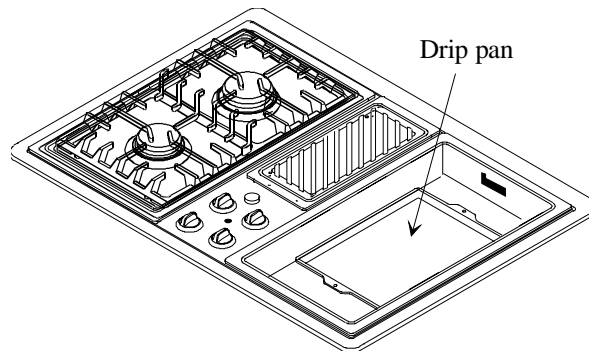



# Cooktop Cartridges (cont'd)

## 3 Place the grill burner in cooktop

Place end of cartridge into cooktop well with air shutters facing rear of well. Venturi should slide over orifice hoods as far as possible.

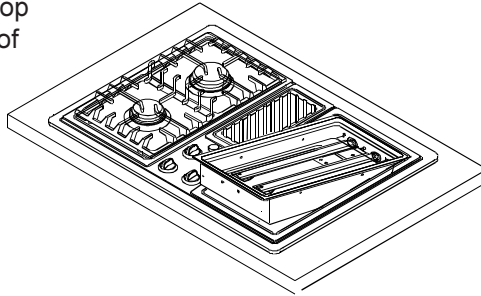

## CAUTION

To avoid risk of personal property damage, do not place the griddle accessory over the grill grate. The griddle accessory is to be placed directly over the grill burner only.

## 4 Place grill or griddle over the grill burner

Only the grill grate or the griddle accessory can be used at one time. The griddle can not be placed on top of the grill grate.

Griddle accessory must be placed so the grease trap is toward the rear of the cooktop.

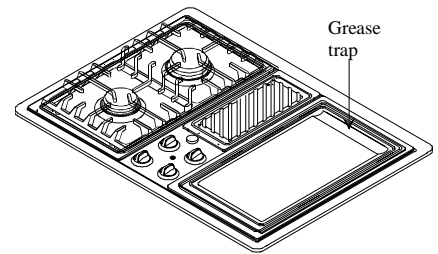
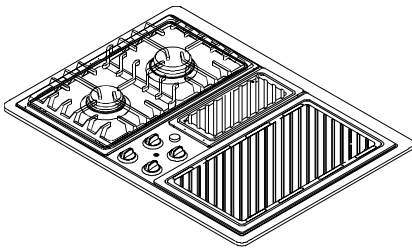

### To remove the grill cartridge:

1. Turn all controls to OFF position.
2. Verify the cartridge and surface of grill/griddle is cool to the touch.
3. Remove grill grate or griddle accessory from cartridge.
4. Remove burner cartridge.
  - Do not tilt cartridge too high. Lifting element over 45° can cause damage to burner venturi.
5. Remove drip pan.
  - Clean drip pan before next use.

# Adjusting Surface Burner Flame

Adjustments must conform to all local, municipal and state building codes, and local utility regulations.

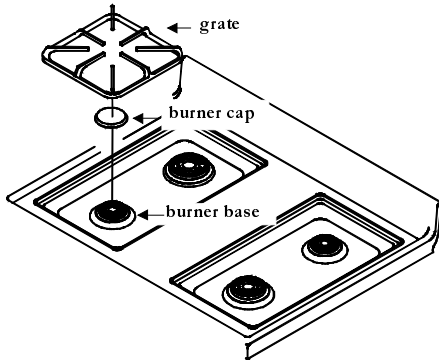

## Placing burner caps

Burner cap must be correctly seated on the burner base for proper operation of the burner. Verify cap is properly aligned and leveled by moving the burner cap around on burner base while cooktop is cool.

- The cap should not be loose.
- The pegs in the burner base should fit into the recess on the underside of burner cap.
- Cap should be the correct size for each burner base.
- Cap must be clean and dry for proper ignition.
- Once cap is properly positioned, place grate over cap and burner base.

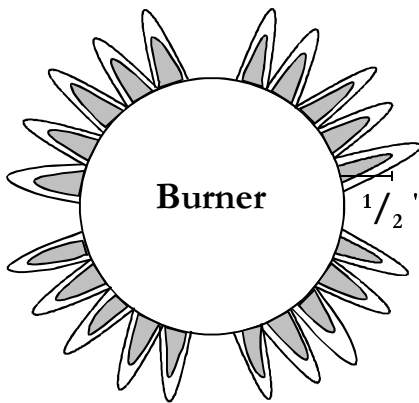

## Testing and adjusting surface burner flame

A properly adjusted surface burner on a high setting has flames that are clean and blue with a distinct inner cone approximately  $\frac{1}{4}$  to  $\frac{1}{2}$ " long.

- See *Delayed Ignition* section in Important Safety Information for safety warnings and procedures.
- **Flames will not be a uniform size around the cap. This distribution around the cap and grate allows for optimal heating.**
- If burner flame is blowing or noisy, airflow should be reduced to the burner (close air shutter).
- If burner flame is weak and does not hold its shape, airflow should be increased to the burner (open air shutter).

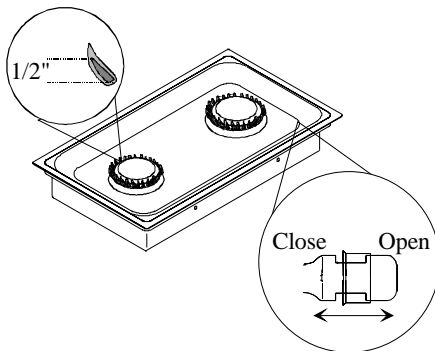

## Adjusting Surface Burner Flame

1. Turn controls to *OFF* position.
2. Remove grate and burner caps from cartridge.
3. Remove cartridge according to *Cooktop Cartridges*.
4. Locate air shutters on rear of cartridge.
5. Adjust each air shutter using small screw driver.
  - Slide air shutter until shutter is approximately  $\frac{1}{8}$  inch open.
6. Replace cartridge according to *Cooktop Cartridges* and check for proper flame.
7. Replace burner grate when flame is properly adjusted.

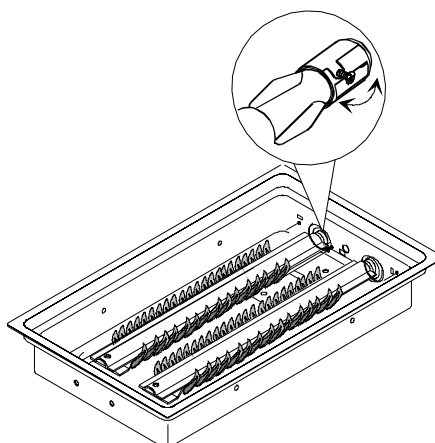

## Adjusting Grill Cartridge Burner Flame

1. Turn controls to *OFF* position.
2. Remove grill or griddle from cartridge if necessary.
3. Remove cartridge according to *Cooktop Cartridges*.
4. Locate air shutters on rear of cartridge, loosen air shutter lock screw, and open or close air shutter.
  - Tighten air shutter lock screw after adjusting.
5. Replace cartridge according to *Cooktop Cartridges* and check for proper flame.



# Cookware Recommendations

## What Should You Consider in Cookware?

SELECT	AVOID
Flat bottomed cookware.	Cookware with rounded or warped bottoms.
Heavy gauge metal cookware.	Light gauge metal cookware.
Handles that are secure, that are not heavy enough to tilt pan.	Cookware with loose or broken handles or heavy handles that tip pan when empty.
Proper pan size.	Cookware that is smaller than or greater than burner grate by 1 inch.
Flat bottomed wok	Wok with a ringstand on bottom.

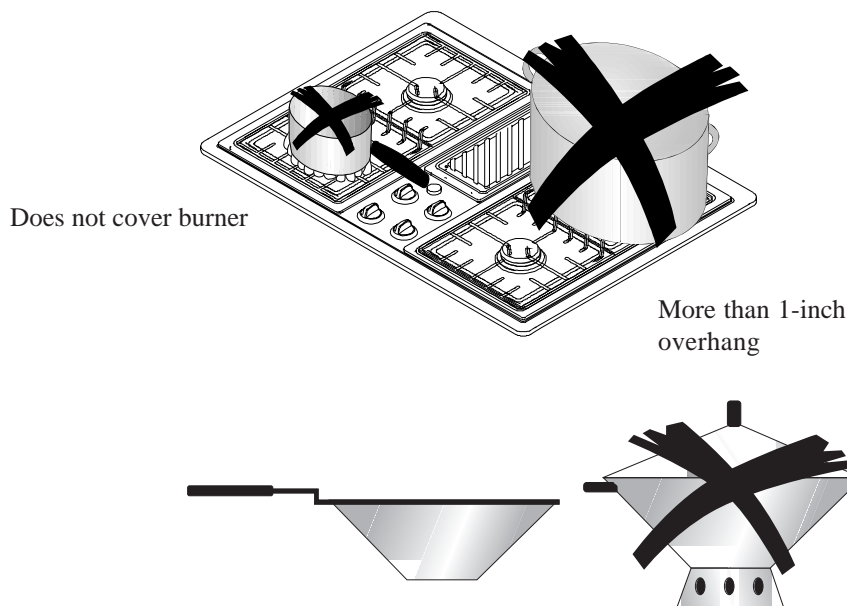

## Flat Pan Test

For best cooking results, use a pan with a flat bottom. To determine if pan has a flat bottom:

1. Rotate a ruler along bottom of pan. If pan is not flat, gaps between bottom of pan and edge of ruler can be seen.
2. A small groove or mark on a pan does not affect cooking times. However, if a pan has a gap, formed rings, or an uneven bottom, it does not cook efficiently and in some cases may not boil liquid.

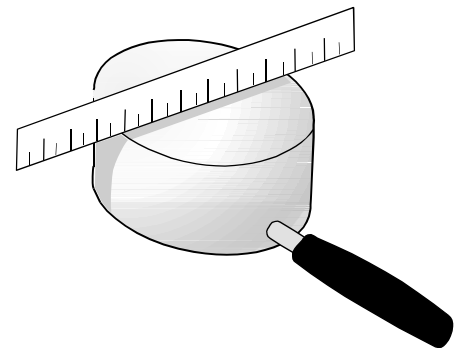

COOKWARE MATERIAL	USES
<b>Aluminum</b>	Heats and cools quickly. Use for frying, braising, and roasting.
<b>Stainless Steel</b>	Heats and cools at moderate rate. Use for soups, sauces, vegetables, general cooking.
<b>Copper Clad / Tin Lined</b>	Heats and cools quickly. Use for gourmet cooking, wine sauces, egg dishes.
<b>Cast Iron</b>	Heats and cools slowly. Use for low heat cooking, frying.
<b>Enamelware</b>	Heating speed depends on base metal in the cookware. Use for low heat cooking.
<b>Ceramic (Glass)</b>	Heats and cools slowly. Use for low heat cooking.

## Can I can?

**Canning is not recommended with any of the Amana gas ranges or cooktops due to the intense heat and large cookware required to can.**

The high, sustained heat generated by the canning cookware overheats both the burners and the surface of the range or cooktop. This may cause damage to burners, knobs, or finish, and may even cause overheating of surrounding walls.

Damage incurred by canning, or attempting to can, is not covered under warranty.

# Using the Cooktop



## WARNING

To avoid risk of serious personal injury, property damage, or fire, do not leave surface burners unattended while in operation. Grease and spillovers can ignite causing a fire.

## Delayed Ignition

Burner should ignite within 4 seconds. If burner does not ignite within 4 seconds turn control knob to OFF position and follow directions in *Adjusting Surface Burner Flame* section. Try burner again. If burner still does not ignite in 4 seconds, contact an authorized servicer.



## WARNING

To avoid risk of personal injury or property damage due to excessive smoke or fire do not attempt to use grill or griddle when power is not available. Fan must be running to exhaust smoke and fumes.

## During a Power Outage

Although the system that lights the burners is electric, surface burners can be ignited during a power outage.

**Never attempt to light grill burner (for grill or griddle use) during a power failure.**

1. Hold match at base of desired surface burner.
2. Push in burner control knob and turn to LITE position.
3. After gas ignites, remove match from burner and turn burner control knob to desired setting.

## Setting Surface Burner Controls

Burner should ignite within 4 seconds. If burner does not ignite within 4 seconds, turn control knob to OFF position and follow directions in *Adjusting Surface Burner Flame* section.

1. Push in and turn control knob to LITE.
  - Burner should ignite within 4 seconds.
  - Burner sparks until knob is turned from *LITE*.
2. After gas ignites, turn control knob to desired setting.
  - Knobs do not have distinct 'clicks'.
  - Use HI to bring food to boiling temperatures. When food is boiling temperature setting should be reduced.
  - After lighting burner do not operate for long periods of time without cookware on grate. The finish on the grate can chip without cookware to absorb the heat.
  - Flame size should match the size of the pan. Do not allow the flame to extend up the sides of the pan. This can cause clothing to ignite, make the handle hot, or cause burns.
3. When finished cooking, turn control knob to OFF position.

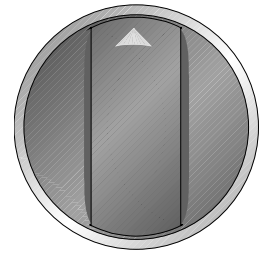

SURFACE ELEMENT CONTROL SETTINGS	WHEN TO USE SETTING
LO	Use to prepare food at less than boiling temperatures or to simmer.
MED	Use to maintain boiling of larger amounts of food, low temperature frying.
HI	Use to bring food to boiling temperatures. When food is boiling temperature setting should be reduced to LO through MED.

## Proper Burner Flame Size

- While turning burner control knob, watch the burner flame.
- Flame size should match the size of the pan.
- Flames that extend up the sides of the pan can ignite clothing, making the handle hot, or cause burns.

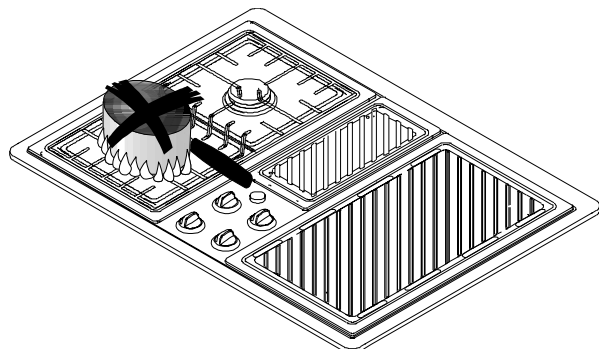

## Using the Smoke Control Grill or Griddle

Before using the grill grate or griddle accessory for the first time, wash it with warm soapy water, rinse, and dry thoroughly. Lightly wipe the top of the grill or griddle surface with cooking oil to prevent food from sticking (do not use shortening or butter). Do not use metal cooking utensils on either the grill or griddle.

1. While cooktop is cool, insert grill burner in cooktop well.
2. Place grill grate OR griddle accessory over the burner.
2. Push in right front and right rear and control knobs and turn.
  - Burner sparks until burner control knob is turned from **LITE**.
  - If using the grill, allow it to preheat for approximately 10 minutes at MED HI.
  - Fan turns on at low speed.
  - If the rear knob is used, the indicator light glows but the grill will not heat, and the fan will not operate.
  - Grill or griddle should not be set at HI setting without food. It will damage the non stick finish.
3. Place food on cooking surface.
  - If food begins to cook too quickly, reduce heat.
  - When using the griddle, do not allow grease to accumulate.
4. When finished cooking, turn control to OFF and allow cartridge to cool.
5. Once cool, clean the pan and the grill grate or griddle. Do not clean the grill burner. Any residue left on the actual burner will burn off with future use.
  - Do not use abrasive cleaners that may harm the non stick finish.
  - Grill grate and griddle may be washed in a dishwasher.



### Exhaust Fan

The variable speed fan is built into the center of the cooktop. The fan is located beneath the vent area and is used to remove cooking vapors, odors and smoke.

- The fan automatically turns on at low speed when using grill or griddle.
- Fan must be manually turned to high speed.
- Fan cannot be turned off while grill or griddle are operating.
- Clean fan vents and filters frequently. Grease should not be allowed to accumulate on vent or filter.



### WARNING

To avoid risk of serious personal injury, property damage, or fire, do not leave surface burners unattended while in operation. Grease and spillovers can ignite causing a fire.



### WARNING

To avoid risk of smoke damage or fire, do not operate cooktop without filter.

### Removing Vent Filter

1. Lift filter cover to remove vent filter.
  - Duct filter lifts out of vent.
2. Clean and reinstall filter and vent cover.
  - Clean in the dishwasher or with damp cloth and warm soapy water.

# Care and Cleaning

Part	Suggested Materials	General Directions And Recommendations
<b>Burner caps and grates</b>	Soap and warm water	Cool before cleaning. Frequent cleaning with soap and water, and non-abrasive pad prolongs time between deep cleanings. Be sure to dry thoroughly.
<b>Hard to clean burner caps and grates</b>	½ Cup Ammonia	Place burner caps and grates in plastic bag with ½ cup ammonia. <b>Do not pour ammonia into bag.</b> Ammonia must remain in cup. To avoid rust, do not soak grates in ammonia. Close bag tightly and leave grate and caps overnight. Before bag is opened turn face away to avoid breathing or eye contact with fumes. Remove burner caps and grates from bag and rinse. Clean according to instructions above.
<b>Gas burners</b>	None	Burners <b>do not</b> need to be cleaned. Soil will burn off while cooking
<b>Cooktop trim</b>	Soap and warm water	Clean cooktop trim with damp cloth and soapy water. If necessary, clean with nonabrasive cleaners or pads. Dry thoroughly when finished to avoid rusting. Do not use harsh powders, oven cleaners, scouring pads, or steel wool.
<b>Control knobs</b>	Mild soap and warm water	Pull off knobs. Wash gently but do not soak. Dry and return controls to cooktop, making sure to match flat area on the knob to the flat area on shaft.
<b>Fan cover and filter</b>	Soap and warm water, or dishwasher	Fan must be off before removing filter cover. Clean filter and cover with damp cloth and soapy water. To remove grease and dried on soil, soak before cleaning. Rinse and dry after cleaning. Filter and filter cover can be cleaned in dishwasher. Always replace filter and cover before operating cooktop.
<b>Grill grate or griddle accessory</b>	Dishwasher or Soap and a non abrasive scrubbing pad	Clean in the dishwasher or with damp cloth and soapy water. If necessary, clean with nonabrasive cleaners or pads. Rinse and dry.
<b>Drip pan, cartridge pan, or drip bowls</b>	Soap and warm water	Allow cooktop to cool before cleaning. Clean with damp cloth and soapy water. Rinse and dry thoroughly. For extra dried on soil, soak the drip bowls in warm soapy water.
<b>Glass control panel and gasket</b>	Soap and warm water	Remove panel and gasket: <ol style="list-style-type: none"> <li>1. Pull knobs off stems to remove.</li> <li>2. Lift glass out of control panel.</li> <li>3. Lift gasket out of control panel.</li> <li>4. Replace gasket and knobs after cleaning.</li> </ol>

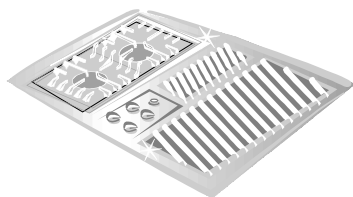

## Caring for Stainless Steel

Amana's stainless steel appliances have been factory finished for high shine and luster. To maintain this quality appearance:

### DO USE:

- Warm soapy water for routine cleaning on a cool cooktop.
- Dry with soft, clean cloth.
- For heavy soil, **ONLY** a stainless steel cleaner designed for kitchen appliance use.

### DO NOT USE:

- Abrasive powders or liquids
- Citrus based cleaners
- Ammonia
- Steel wool pads
- Abrasive cloths
- Oven cleansers
- Acidic or vinegar based





### Citric Acid

To prevent damage to the finish of your stainless steel cooktop, do not allow mustard, tomato juice, marinara sauce, or other citrus based sauces or products to remain on stainless steel surface. Citric acid permanently discolors stainless steel.

# Troubleshooting

You may save time and money by checking items below before calling for service. List includes common concerns that are not the result of defective workmanship or materials. If your question is not explained below, contact Amana Consumer Affairs Department at **800-843-0304** or visit our website at [www.amana.com](http://www.amana.com)

Topic	Possible Cause	Solution
<b>OPERATION</b> 		
<b>Appliance not working</b>	Power outage	Make sure appliance is plugged in. Verify that circuit breaker is not tripped. Replace fuse but do not change fuse capacity.
<b>Control knobs do not turn</b>	Normal	Push knob in and then turn.
<b>Surface burners do not light</b>	Improper Installation	Turn knob to OFF. Remove cartridge and install according to instructions in <i>Cooktop Cartridges</i> section.
<b>NOISE</b> 		
<b>Roaring or loud flame sound</b>	Improper air shutter setting	Adjust air shutter.
<b>Cracking or popping sound</b>	Normal	Wet cooking utensils or possible spillage.
<b>APPEARANCE</b> 		
<b>Discoloration</b>	Dirt Water spots/marks	Use recommended cleaner to remove dirt Make sure surface is cool. Put a small amount of white vinegar on the spot and let sit for a few minutes. Rub with nonabrasive nylon pad. Wipe off any excess with damp paper towel.



*Questions on cooking, cleaning or usage?*

Refer to

Product Assistance at [www.amana.com](http://www.amana.com)

OR

call Consumer Affairs at **1-800-843-0304**







# Amana Warranty

## Full ONE Year Warranty

Amana Appliances will repair or replace, including related labor and travel, any part (f.o.b. Amana Iowa) which proves defective as to workmanship or materials.

## Limited Warranty

After one year from the date of original retail purchase, Amana will provide a free part, as listed below, to replace any part that fails due to a defect in materials or workmanship. The owner will be responsible for paying all other costs including labor, mileage, and transportation.

## Second through Fifth Year

Amana will replace glass/ceramic cooktop, electric surface elements or gas surface burners, part only (f.o.b. Amana Iowa) which proves defective as to workmanship or materials.

## What is not covered by these warranties

- Replacement of household fuses, resetting of circuit breakers, or correction to household wiring or plumbing.
- Normal product maintenance and cleaning, including light bulbs.
- Products with original serial numbers removed, altered, or not readily determined.
- Products purchased for commercial, industrial, rental, or leased use.
- Products located outside of the United States or Canada.
- Premium service charges, if the servicer is requested to perform service in addition to normal service or outside normal service hours or area.
- Adjustments after the first year.
- Repairs resulting from the following:
  - Improper installation, exhaust system, or maintenance.
  - Any modification, alteration, or adjustment not authorized by Amana.
  - Accident, misuse, abuse, fire, flood, or acts of nature.
  - Connections to improper electrical current, voltage supply, or gas supply.
  - Use of improper pans, containers, or accessories that cause damage to the product.

## To Receive Warranty Service

Service must be performed by an authorized Amana service representative. To schedule service, contact the Amana dealer where you purchased your appliance or contact Amana Appliances Factory Service.

**Amana Appliances Factory Service**  
1-800-628-5782 inside USA

## When contacting Amana Appliances please include the following information:

- Your name, address, and daytime telephone number.
- Model number and serial number of your appliance (located on the underside of the cooktop).
- The name and address of your dealer and the date of purchase.
- A clear description of the problem.
- Proof of purchase (sales receipt).

**For more information,**  
**Amana Appliances Consumer Affairs**  
Amana Appliances  
2800 220th Trail  
Amana, Iowa 52204  
1-800-843-0304 inside USA  
(319) 622-5511 worldwide

## IN NO EVENT SHALL AMANA BE LIABLE FOR INCIDENTAL OR CONSEQUENTIAL DAMAGES.

This warranty gives you specific legal rights, and you may have others which vary from state to state. For example, some states do not allow the exclusion or limitation of incidental or consequential damages, so this exclusion may not apply to you.

**Amana Appliances Online • <http://www.amana.com>**